

**TOP**

GAS (TOP) / LIQUID (BOTTOM)  
PASS-THRU SLOT INSIDE TANK

HORIZONTAL STRUCTURAL REINFORCING RIBS  
(FULL CIRCUMFERENCE)

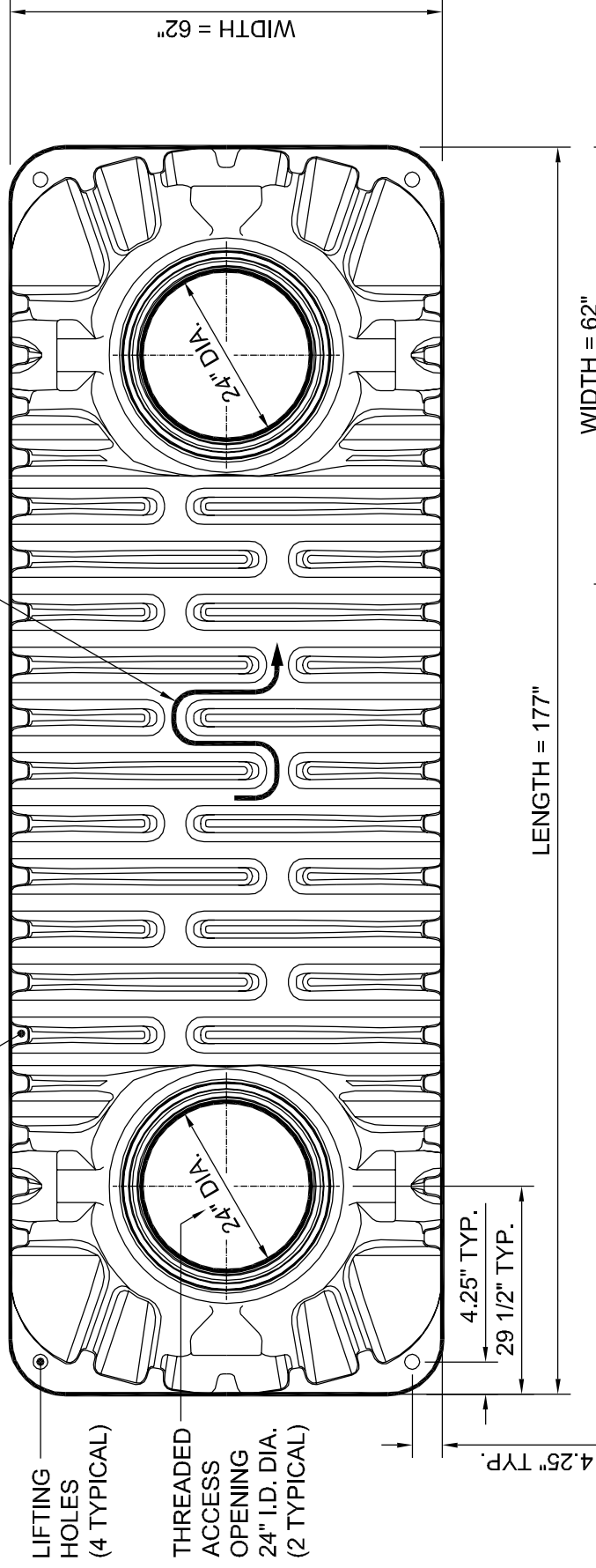

LIFTING HOLES (4 TYPICAL)

THREADED ACCESS OPENING 24" I.D. DIA. (2 TYPICAL)

**TANK SPECIFICATIONS**

DESIGN CAPACITY		TOTAL CAPACITY		WEIGHT	
GALLONS	LITERS	GALLONS	LITERS	POUNDS	POUNDS
1500	5678	1771	6692	640	640

**SIDE**

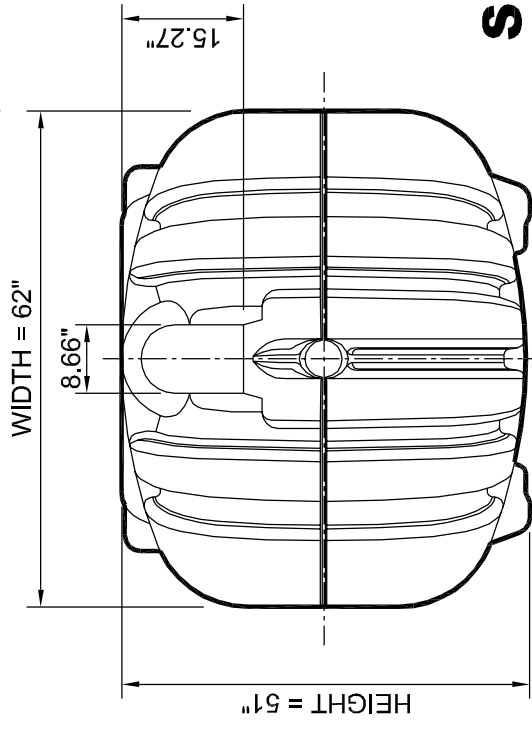

# ELEVATION

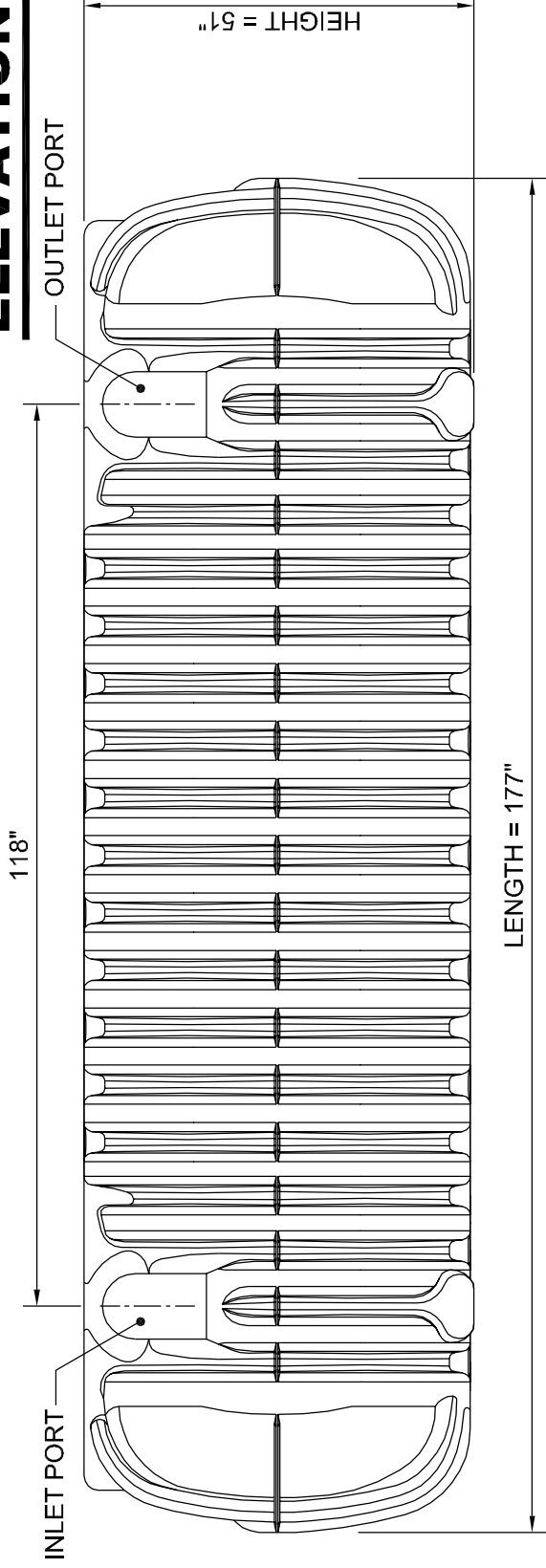

# SECTION

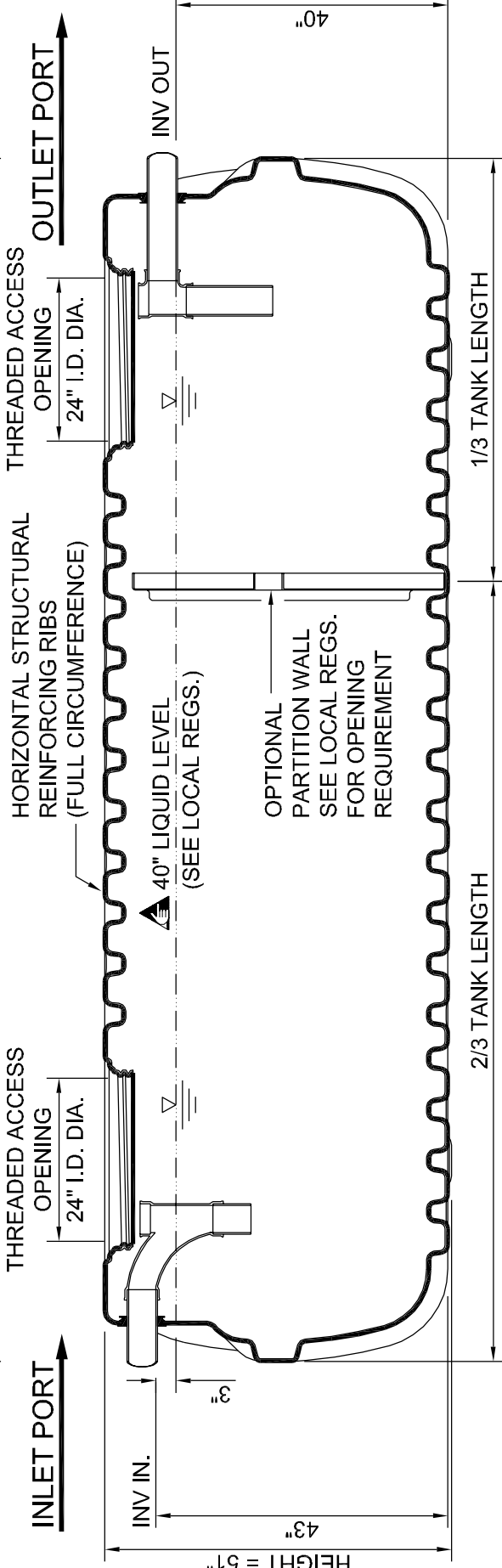

# 40" LIQUID LEVEL



# ISOMETRIC

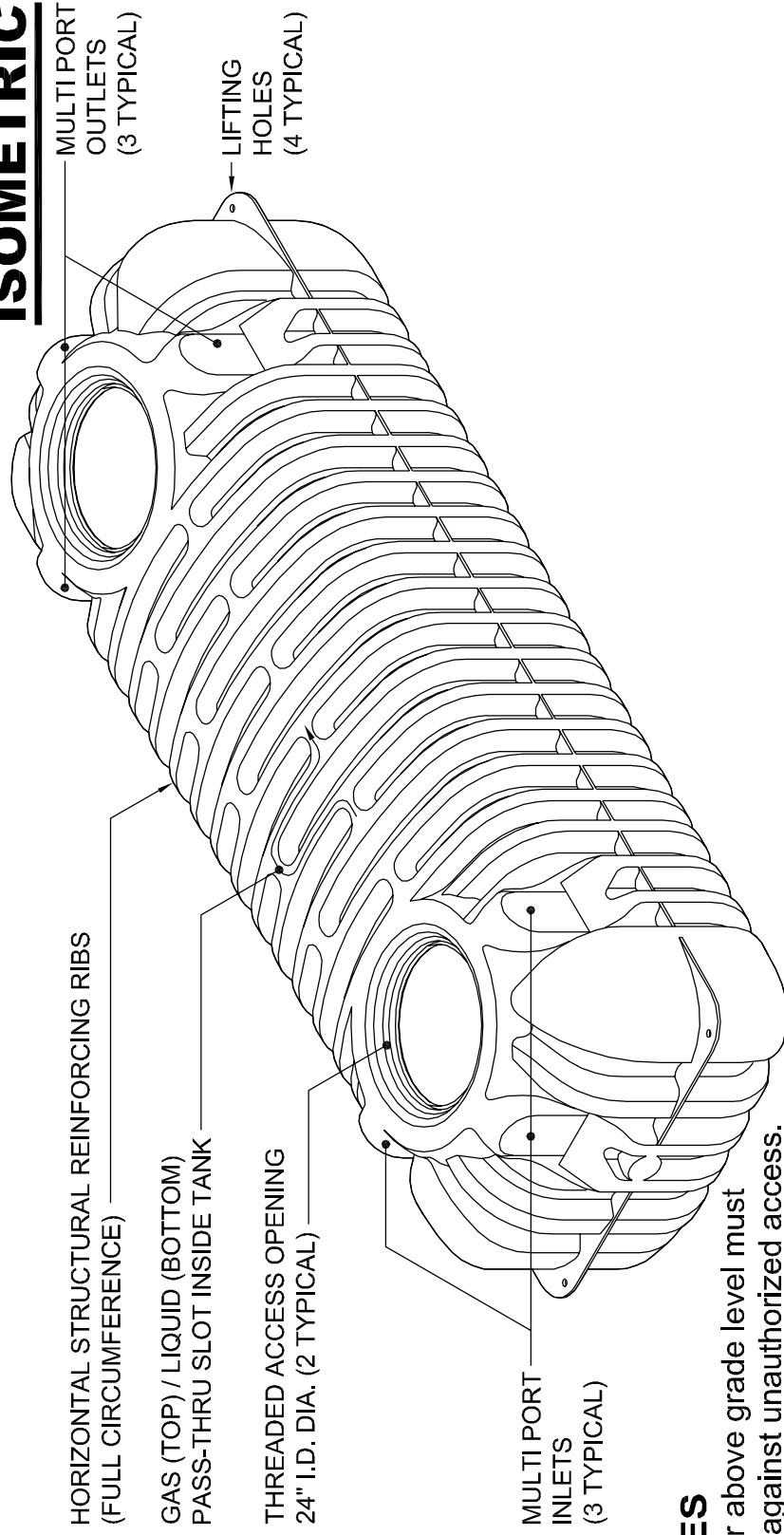

HORIZONTAL STRUCTURAL REINFORCING RIBS  
(FULL CIRCUMFERENCE)

GAS (TOP) / LIQUID (BOTTOM)  
PASS-THRU SLOT INSIDE TANK

THREADED ACCESS OPENING  
24" I.D. DIA. (2 TYPICAL)

MULTI PORT  
INLETS  
(3 TYPICAL)

MULTI PORT  
OUTLETS  
(3 TYPICAL)

LIFTING  
HOLES  
(4 TYPICAL)



## TANK NOTES

1. Access at or above grade level must be secured against unauthorized access.
2. Tank is not rated for vehicular traffic loading.
3. All resin used is compliant with ASTM D 1248 as required by CSA B66 and IAPMO / ANSI Z1000-2007.
4. Tank material of construction is HMW-HDPE.
5. Primary dimensions are in inches
6. Minimum tank wall thickness is 1/4".
7. Labeling will include: manufacturer name, liquid capacity, date, maximum burial depth, and model number.
8. Riser cover contains the following: 6" x 3" warning:  
"Danger - Do not enter - Poison Gas" - written in English, French & Spanish.
9. Maximum burial depth from manufacturer is 36" unless specifically instructed otherwise by the factory.
10. Models RMT-750, RMT-1060, RMT-1250 and RMT-1500 are all certified to CSA and IAPMO standards.
11. Models RMT-500, RMT-900 and RMT-1000E are compliant with CSA and IAPMO standards.

# NOTES